

3-SPEED CRANK AXLE GEARBOX



楽しい工作シリーズNO.93 3速クランクギヤボックスセット

TAMIYA

WARNING: This set contains small parts which may be hazardous to children under three. This toy is battery operated. Follow instructions for proper battery installation. This set contains parts which have sharp points and edges. Sand jagged edges before use. Keep fingers free from moving parts. Product may overheat during prolonged use.

CAUTION: Read instructions carefully before use. Assembly required. Tools not included.

1

ギヤケースのくみ立て GEARBOX ASSEMBLY

★グリスをさします。
★Apply grease.

《高速》
HIGH SPEED

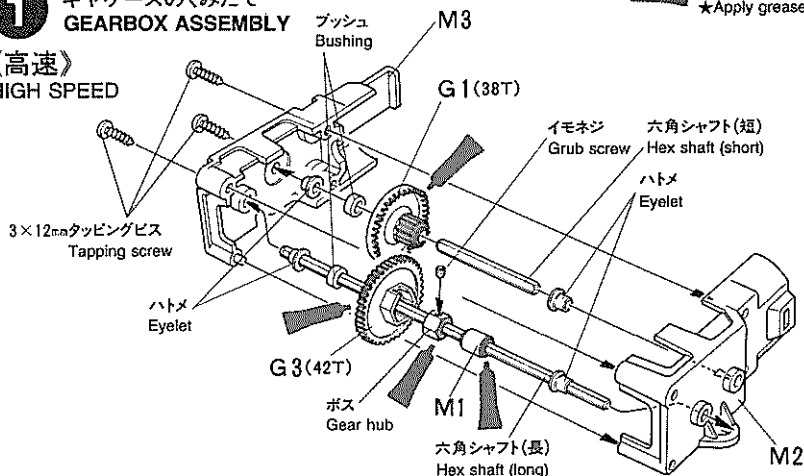

《中速》
MID SPEED

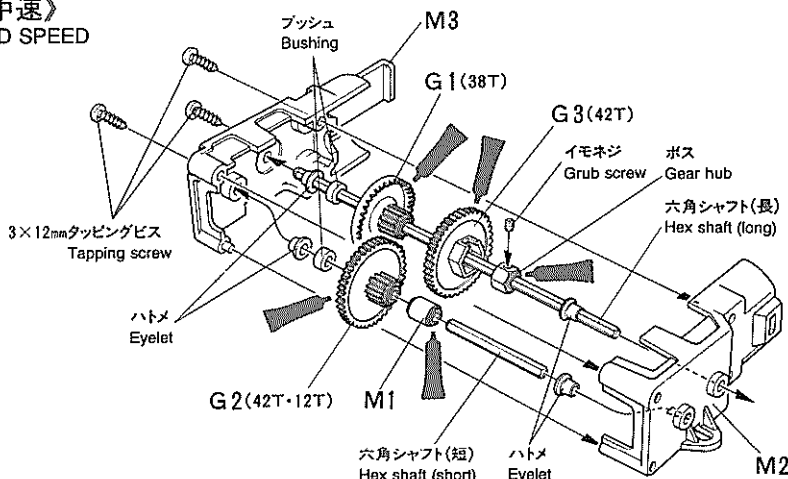

《低速》
LOW SPEED

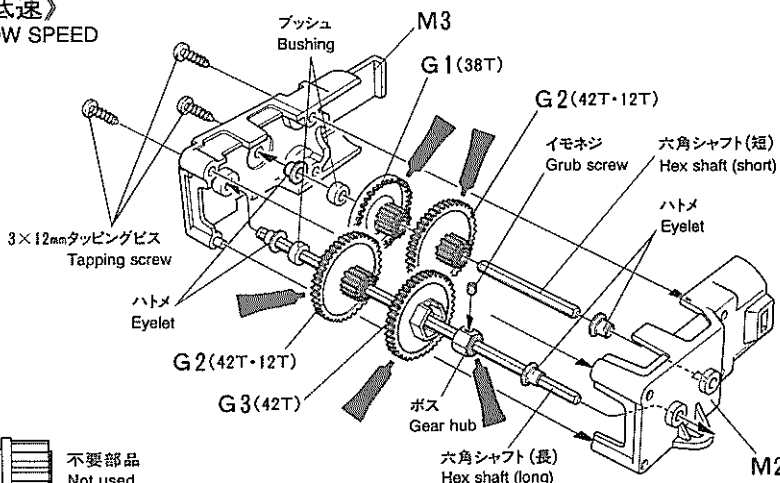

不要部品
Not used.

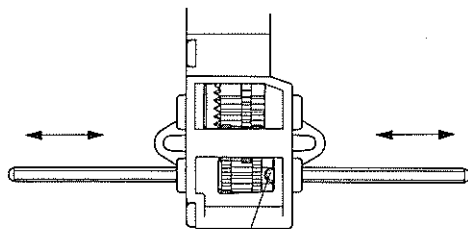
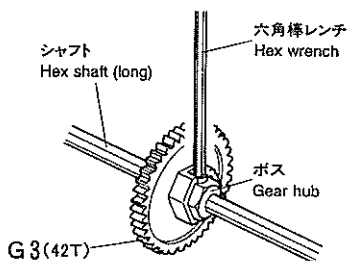
2**シャフト位置の調節
SHAFT ADJUSTMENT**

- ★イモネジをゆるめ、製作する模型に合わせてシャフトの長さを調節します。
★Loosen grub screw and move shaft right or left according to use.

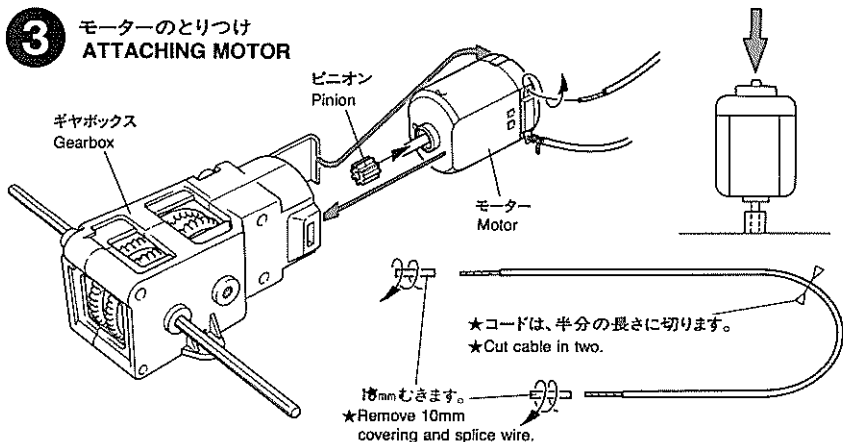
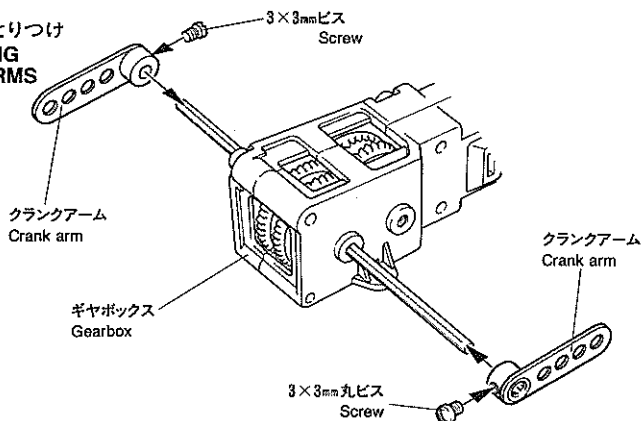
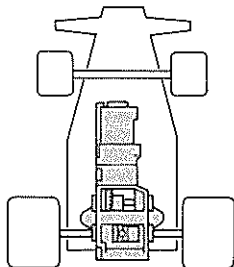
3**モーターのとりつけ
ATTACHING MOTOR****4****クランクのとりつけ
ATTACHING CRANK ARMS****EXAMPLES (3速クランクギヤの応用例)****高速(自動車に) HIGH SPEED**

2つのギヤを組み合わせせた高速仕様はギヤ比16.6:1。自動車工作など、スピードが必要な工作に最適です。

High speed setting of this gearbox provide a 16:1 ratio gearing, which is suitable for car model etc.

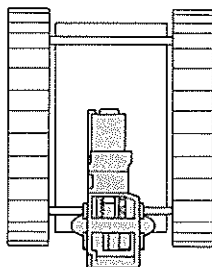
**中速(キャタピラに) MID SPEED**

3つのギヤを組み合わせせた中速仕様はギヤ比58.2:1。タンク工作などが必要な工作に適しています。

The 58:1 ratio mid-speed gearing can produce powerful torque required for tracked vehicle models, buggies, etc.

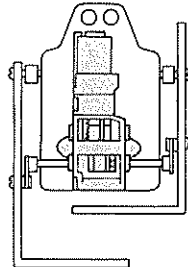
**低速(ロボットに) LOW SPEED**

4つのギヤを組み合わせせた低速仕様はギヤ比は203.7:1。ゆっくりした回転で大きな力が取出せるのが特徴です。

An extremely slow operation speed can be obtained using the low speed, 203:1 ratio setting of this gearbox. Suitable for a walking robot etc.